

PRODUCT INFORMATION

EXTERNAL EXHAUST VALVE

External Exhaust Valve G3 Series

- Model G3-M/G3-ME
- Model G3-H/G3-HE



■ Feature 1

The specially designed air-operated valve prevents leaks, small volume change, and temperature change that could cause errors in leak test.

■ Feature 2

To prevent the malfunction of the exhaust valve due to dust, the sliding part and the detection circuit are separated from each other*¹. The ports to be connected to the tested part and the master are provided with special filters*².

*¹ G3-M/G3-ME *² G3-M/G3-H

■ Feature 3

Since large flow can be used, there is almost no effect on the pressurization time and exhaust time for the tested part.

■ Feature 4

The integrated structure enables air to be exhausted simultaneously on the tested part and master sides. The External Exhaust Valve is controlled by the leak tester with the option of External Exhaust Valve.

The external exhaust valve is attached to the line between the leak tester and a tested part to exhaust the air after a leak test is finished. It keeps foreign materials, such as water, oil and dust, in the tested part and line from entering into the tester, thus preventing malfunction and quality degradation.

Use of the external exhaust valve is especially recommended for a tester that uses air leak test in combination with water submersion visual inspection.

(*The ingress of foreign materials may not be prevented under some conditions.)

■ Specifications

	G3-M/(G3-ME)	G3-H/(G3-HE)
Maximum operating pressure	800 kPa	4.9 MPa
Proof pressure	1.0 MPa	7.5 MPa
Port size	Rc1/4	
Pilot pressure	400 to 700 kPa (Supplied from the leak tester)	
Accessory	For pilot pressure Pipe outer diameter 4 mm, Length 3 m	
External dimensions	W116 L110(65) H100 mm Including the mounting brackets and parts	W116 L118(65) H112 mm Including the mounting brackets and parts
Applicable Leak Tester	Leak testers with the option of Low/Medium-pressure External Exhaust Valve	Leak testers with the option for high-pressure External Exhaust Valve

■ Pneumatic Circuit System

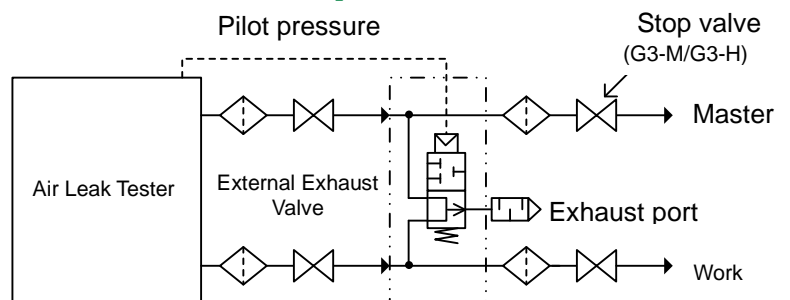

- * The length of the pilot pressure pipe must be up to 3 m. Otherwise, malfunctions could occur.
- * Install the External Exhaust Valve horizontally, as close to the tested part (Work) as possible and lower than the leak tester.
- * For details, refer to the operation manual of the Air Leak Tester.

- The G3-M/G3-H is equipped with a stop valve, so leak check is easy.
- Mounting brackets are included.
- * The image is G3-H

* The contents of this product information are as of October 2021. The specifications are subject to change without prior notice.

Cosmo Instruments Co., Ltd.

2974-23 Ishikawa, Hachioji, Tokyo 192-0032 Japan

China:	Cosmo (Shanghai) Trading Co., Ltd.	+86-(0)21-6575-6880
	Shanghai, Tianjin, Guangzhou, Chongqing, Changchun, and Wuhan	
Korea:	Cosmo Korea Co., Ltd.	+82-(0)32-623-6961
Taiwan:	Taiwan Cosmo Instruments Co., Ltd.	+886-(0)2-2707-3131
Malaysia:	COSMOWAVE SDN.BHD.	+60-(0)3-51626677
Thailand:	Cosmowave Technology Co., Ltd.	+66-(0)2-7361667
Indonesia:	Pt. Cosmowave	+62-(0)21-42900043
Vietnam:	Cosmowave Technology Co.,Ltd. Vietnam Representative Office	+84-(0)47876085

<http://www.cosmo-k.co.jp/>

Phone: +81-(0)42-642-1357 Fax: +81-(0)42-646-2439

India:	Cosmo Instruments India Pvt. Ltd. Head Office	+91-(0)124-421-0946
	Cosmo Instruments India Pvt. Ltd. South Zone Regional Office	+91-(0)9663384423
	Cosmo Instruments India Pvt. Ltd. Pune - Chakan Office	+91-(0)20-6933-2345
	Cosmo Instruments India Pvt. Ltd. - Chennai Office	+91-(0)9994364454
Germany:	Cosmo EU Solutions Technology GmbH	+49-(0)212-383671-71
USA:	Cosmo Solutions Technology, Inc.	+1-248-488-2580
Mexico:	Cosmo De Mexico	+52 472 748 62 94
Brazil:	Tex Equipamentos Eletronicos Ind. Com. Ltda.	+55-(0)11-4591-2825
Australia:	Industrial Research Technology Pty. Ltd.	+61-(0)412-176-674

G3-985B1-C